

Table of contents

Before Using the Machine for the first time

1.Installation

- 1.Names and functions of respective parts.
- 2.Applicable engine
- 3.Parts to be assembled
 - (1) Unpacking
 - (2) list of parts to be assembled
 - (3) assembling procedure
- 4.Installation and movement
 - (1)Installation
 - (2)movement
 - (3)threading the twine

2.Inspection before operation

- 1.Inspection before operation
 - (1)Inspection of respective parts of engine
 - (2)Inspection of machine proper
- 2.Inspecting at start of engine
- 3.list of oiling and greasing points

3.How to operate

- 1.purpose of machine
- 2.adjustment for operation
 - (1) Film loading
 - (2) Adjustment of side roller
- 3.working procedure
 - (1) Number of turns of film
 - (2)Method for starting the machine
 - (3)Rotating speed of turn table
 - (4)working method

4.After completion of operation

- 1.Care after completion of operation
- 2.For storing the machine for a long period of time

5. Inspection and maintenance

1. Inspection and maintenance table
2. Adjustment relating to start lever

6. Trouble corrections

1. trouble corrections

Before Using the Machine for the first time

Before using the machine for the first time, carry out the following.

1. check the engine oil

Check whether or not a specified quantity of engine oil exists. If it is too small, replenish the oil up filler port without screwing it, and measure. Add oil to the top graduation line of the oil gauge.

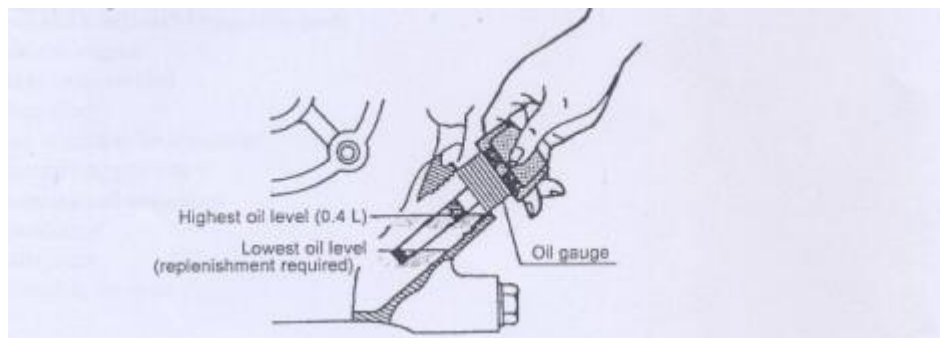

As the oil, use the engine oil for motor vehicles with a viscosity corresponding to the outside air temperature shown in the following table

Oil Viscosity Selection Standard

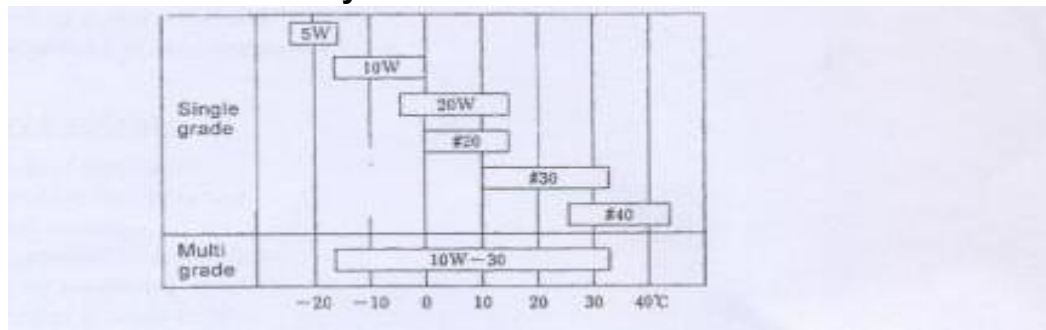

precaution

- If the engine oil declines in quality or quantity, a trouble of seizure can be caused, Use the oil with quality of class SC or higher
- In the case where the outside air temperature is lower than -20°C or higher than 40°C , select the oil with a viscosity and quality suitable for local condition

Note that if an oil of multi grade is used, the oil consumption tends to increase when the air temperature is high

2. Check the quantity of fuel

Use lead-free gasoline for motor vehicles as the fuel

The tank capacity is about 1.5 liters.

Precaution

- For refueling, don't fill up to the entrance of the fuel filler port, and keep the fuel level under the predetermined limit line for refueling. If too much fuel is added, the fuel can bleed from fuel tank cap dangerously

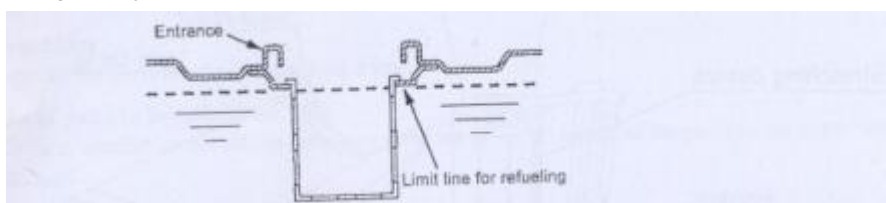

- For refueling, be sure to use the fuel filter screen installed in the fuel filler port

WARNING

- If fire is brought close to the fuel filler port, a fire may break out. Never allow fire to approach it. During refueling, stop the engine
- Entering a wrong fuel is dangerous. Confirm once more whether or not the fuel is right
- If you refuel the engine with a cigarette in your mouth or under a bare light bulb, the fuel may be ignited to burn you. Do not refuel with fire nearby
- If you refuel while the engine is still hot, the fuel may be ignited to burn you. Do not refuel while the engine is still hot
- After completion of refueling, firmly close the fuel cap, and perfectly wipe away the spilling fuel. Otherwise, a fire accident can be caused.

1. Installation

Correctly install for safe operation

1.Names and functions of respective parts

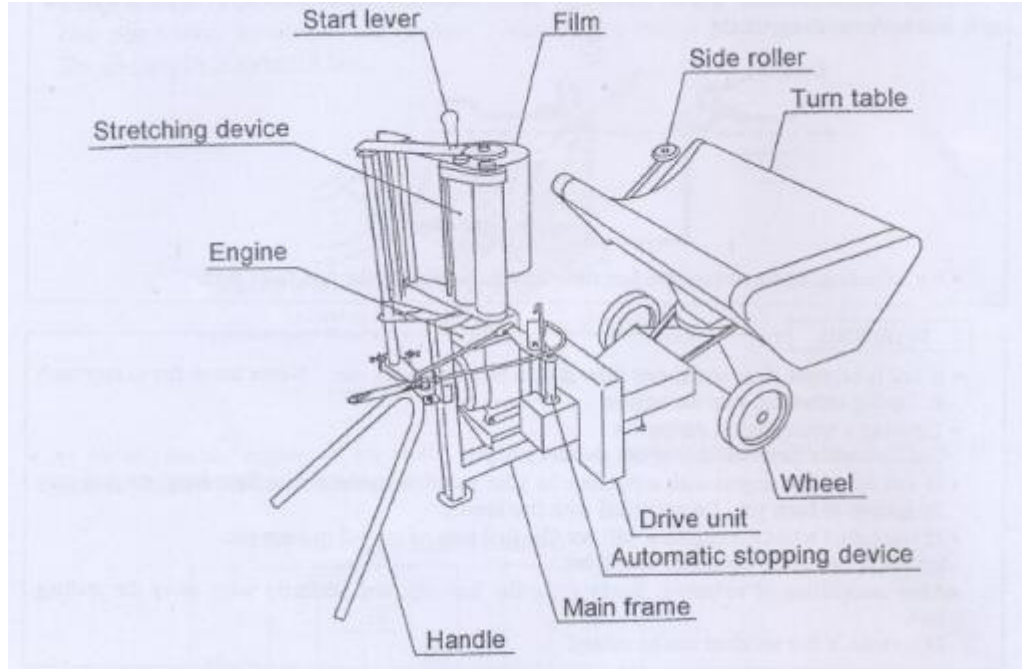

1.Main frame

The main frame supports the engine,drive unit,automatic stopping device,turn table and stretching device

2.Handle and wheels

The handle and wheels support the machine and can be used to work

3.Drive unit

The drive unit decelerates the rotation from engine,and the belt clutch tension is used to transmit the rotation to or to isolate the rotation from the turn table.

4.Automatic stopping device

This device automatically stops the film winding around the bale

5.Turn table

The turn table has a bale mounted on it and turns it for wrapping it

6.Side roller

The roller keeps the bale in position,while the bale is wrapped

7.Stretching device

This device is loaded with a film and stretches the film from the roller driven by the force pulling out the film.

8.start lever

This lever is used to turn on or off the rotation of the turn table

2.Applicable engine

The machine is designed to exhibit its performance when an adequate engine is mounted on it.the engine of the machine has the following specification.

Engine horse power	6hp
	Continuous rating 3600rpm

3.Part to be assembled

1.Unpacking

Remove the parts fixed to the packing frame

2.list of parts to be assembled

Confirm whether or not all the necessary parts are provided based on the packing list contained in the package

3.Assembling of handle

With regard to the bolts and nuts necessary for assembling the respective parts,see the symbols stated in the packing list

(1)Assembling of handle

Assembling the handle on the front side of the main frame of the machine

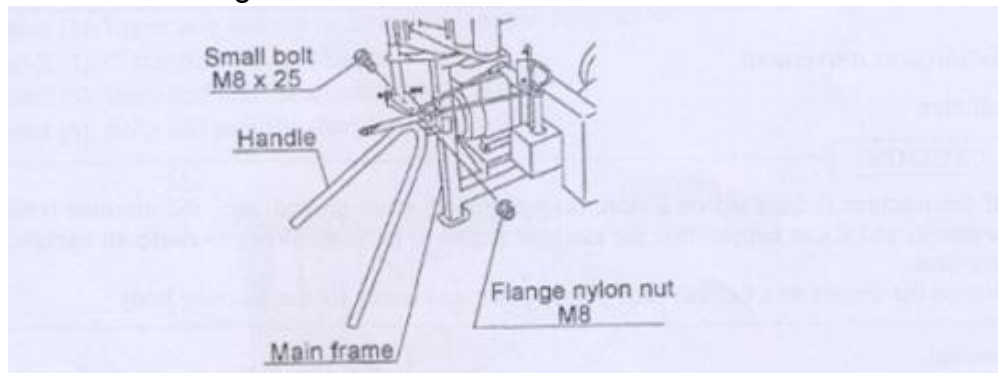

Precaution

- When assembling,adjust the tightening of the bolt and the flange nylon nut to ensure that the handle can be easily moved vertically

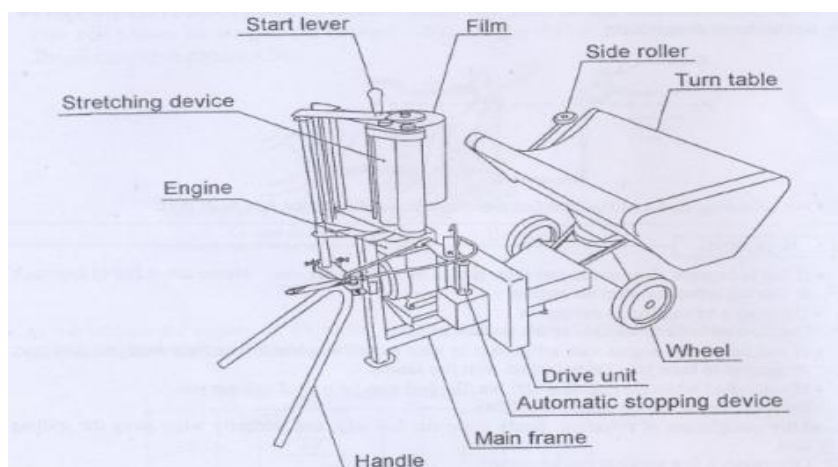

(3)Assembling of start lever

After assembling the stretching device as described in the above 3-3-(2),insert a lever B into the bush portion at the top of the stretching device,and insert the bush into a bottom lever A,fixing using a bolt and a flange nylon nut

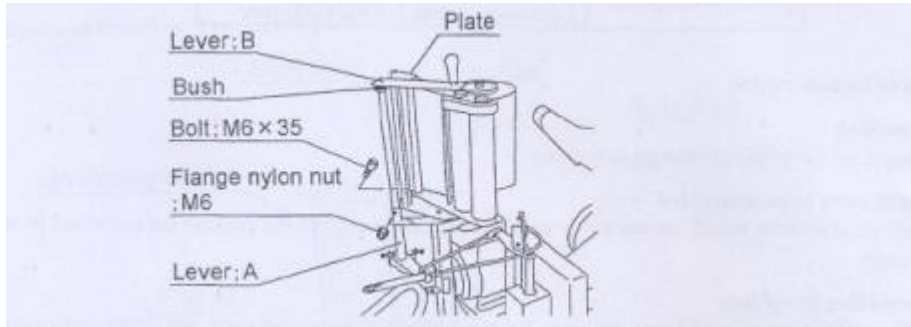

Precaution

- It should be noted that if the bolt and the flange nylon nut are tightened extremely,the pipes of the levers A and B may be deformed

4.Installation and movement

1.Installation

CAUTION

- If the machine is moved at a high speed on a slope,rugged ground or along a sharp curve,it can happen that the machine falls down on its side or tumbles down accidentally.Move slowly
- If the machine is moved on a shoulder of a road with an incling side or side ditch,it can happen that the machine tumbles down accidentally.Don't move on a shoulder
- If it is attempted to move the machine across a large level difference,it can happen that the use a footboard
- If a person rides on the machine,it can happen that the machine falls to injure him.her.Furthermore,if the machine is moved with any thing placed on it,it can happen that the the thing drops or that the machine falls down on its side to injure the persons working nearby.Do not allow any person ot thing to be placed on the machine

Precaution

- In the case where the machine is mounted on the load carrying platform of a truck and fastened using a rope or the like,do not wind the rope around the turn table for fixing it. The machine may be broken

2.Inspection before start of operation

Be sure to inspect the machine before start of operation to ensure that the machine can be used for a long period of time without any problem

CAUTION

- If the inspection before start of operation is neglected, it can happen that the machine is poorly adjusted and broken or that any person working nearby is injured accidentally.
- Before starting operation, inspect the machine based on the instruction manual

1. Inspection before operation

1. Inspection of respective parts of engine

Inspect the respective parts of the engine based on the instruction manual of the engine

2. Inspection of machine proper

(1) Check whether or not the bolts and nuts of respective parts are loose or whether or not pins come off.

Especially check the following parts carefully.

Symbol (1): Bolt and nut for attaching the handle

Symbol (2): Lower bolt and nut for attaching the stretching device

Symbol (3): Upper bolt and nut for attaching the stretching device

Symbol (4): Cotter pins for attaching the wheels

Symbol (5): Bolts and nuts for attaching the engine

Symbol (6): Bolts and nuts for attaching the turn table

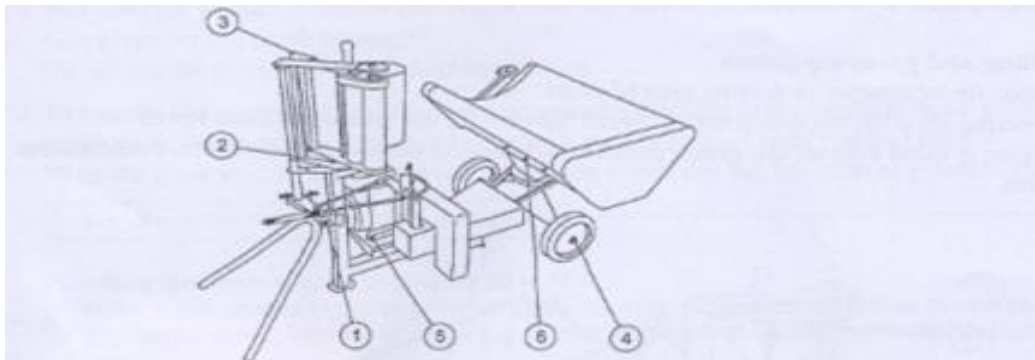

Symbol (7): Bolts and nuts for attaching sprockets 35-20T

Symbol (8): Bolt and nut for attaching sprocket 35-13T

Symbol (9): Chain tension bolt and nut

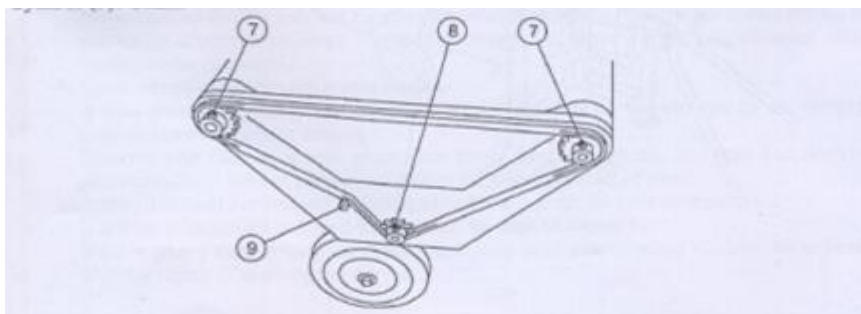

(2) Check whether the chain tension is too tight or too loose

(3) Check whether the oil and grease at respective parts is sufficient

If any oil or grease is insufficient, apply the oil or grease based on the

explanation of “2-3 List of oiling and greasing points.”

2. Inspection at start of engine

WARNING

- Before starting the engine, confirm that the start lever is set at “OFF position.” If the engine is started with the start lever at “ON position,” the turn table will rotate to injure any person working nearby.
- If the engine is started indoors as in a house, the exhaust gas may cause poisoning. Open windows and door for sufficient ventilation.

CAUTION

- Before starting the engine, let the persons working nearby know it and confirm safety.

1. Inspection at start of engine

- (1) Confirm that the start lever is set at “OFF position.”
- (2) Start the engine, and confirm whether or not the engine is normal
- (3) Operate the start lever, to rotate the machine, and confirm whether or not any abnormal sound or abnormal vibration occurs.
- (4) if any trouble is found, correct the trouble based on the “6-1 List trouble corrections.”

3. List of oiling and greasing points

The oil used for lubrication or coating must be clean.

When greasing, do it till the new grease sufficiently when it is delivered.

However, confirm them before use.

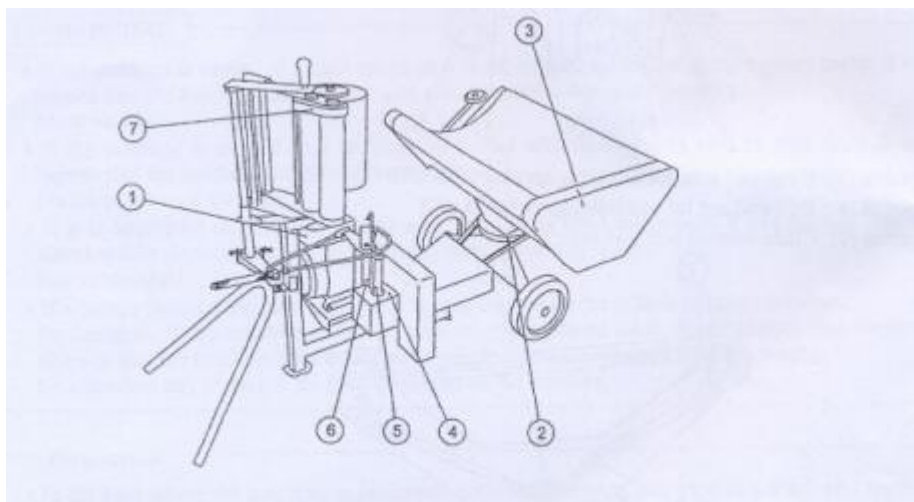

No	Lubrication point	Point	Kind of lubrication	change period	remark
①	Engine	1	Engine oil for motor vehicles		About 0.4 liter

②	Gear (turn table)	1	Greasing coating	Every 30 working hours	
③	Drive chain(turn table)	1	oil	After use	
④	Drive chain(automatic stopping device)	1	oil	After use	
⑤	Slide arm screw(automatic stopping device)	1	oil	After use	
⑥	Side arm shaft face (automatic stopping device)	1	oil	After use	
⑦	Gear (stretching device)	1	Grease coating	Every 30 working hours	
	Bearings and other sliding portions	----	Grease or oil	After use	

※1.For the detail of oiling to the engine(No.1), see the instruction manual for the engine contained in the package.

※2.If the slide arm shaft face (automatic stopping device)(No.6) is coated with a grease with a high viscosity,the movement of the slide arm becomes poor.

3.How to operate

1.Purpose of machine

- 1.this machine is used to stretch and wind a film around a cylindrical bale for sealing it,to prepare bale silage for livestock farming.Do not use the machine for any other application.
- 2.To prepare silage of good quality,do not operate the machine in the case where the grass contains much water due to rainfall or dense fog,or on a muddy field or highly humid field. Wrap the grass with an adequate water content on a well dry field as soon as possible after baling.

For perparing wrapped silage with good

- 1.Adjust the water content of grass to 50 to 60%.if the water content is too large or too small,ideal lactic acid fermentation cannot take place.Especially during rainfall or dense fog,do not operate the machine since the mater content is too large
- 2.Preparation of well-shaped highly dense bales.Make well-shaped highly dense bales
- 3.Sealing immediately after baling.If the sealing is delayed,the temperature inside the bale rises to grow putrefying bacteria and to thermally denature proteins,thereby lowering the digestibility,not allowing silage with good quality to be prepared.
- 4.Use a wrapping film with stable quality.A film like to greatly change in nature in response to the change of air temperature may be poor in the accuracy of sealing.Preserve the film in a cool place free from direct sunshine,to avoid the deterioration during preservation.Do not preserve the film for a long period of time.
- 5.If the film used for sealing is damaged to have a hole,be sure to repair it.If a film is damaged or holed by mistake,be sure to repair it.If an ordinary tape is used for repairing ,it may peel due to water content,solar heat or the like.Use the repair film designated by us

6.Reliable preservation

As the place for preserving the silage,select a well drained place and cover the silage with a net,or spray chemicals, or take any other necessary measure for protecting the

silage from damage caused by birds, rodents, insects, etc.

It is ideal to stack the wrapped bales vertically in two or three stages, for maintaining the sealing accuracy and saving the preserving space.

The number of stages must be such that the stacked bales do not fall but remain stable and safe.

7. All the unsealed bales should be consumed for feeding within the day.

If silage is exposed to air, secondary fermentation occurs to promote deterioration.

2. Adjustment for Operation

1. film loading

(1) Remove the beta pin and rollers of the stretching device portion, and set a film. Then, insert a roller into the cylindrical hole at the top of the film, and fix using the beta pin.

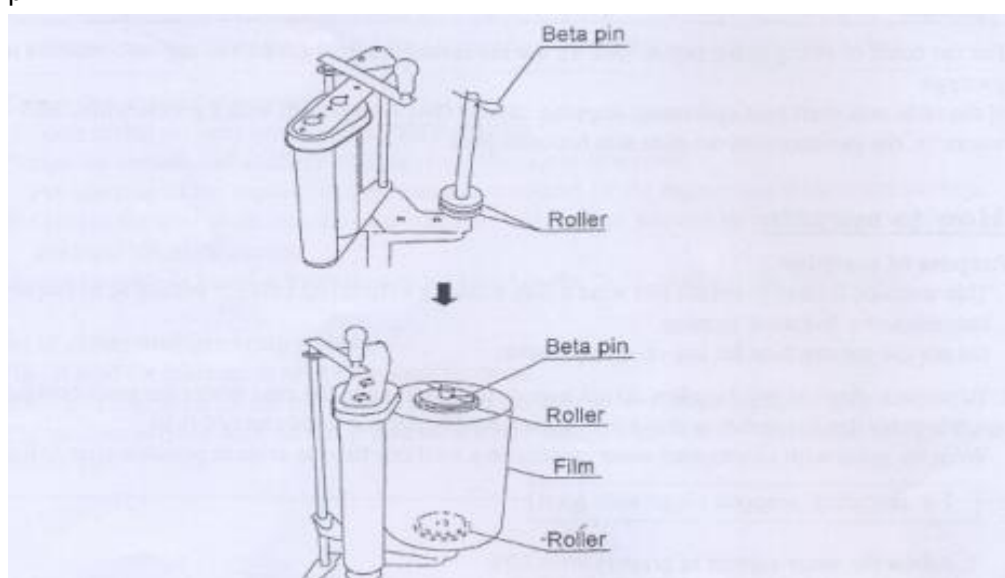

(2) Insert the film in such a manner that the winding direction observed from above corresponds to counterclockwise direction.

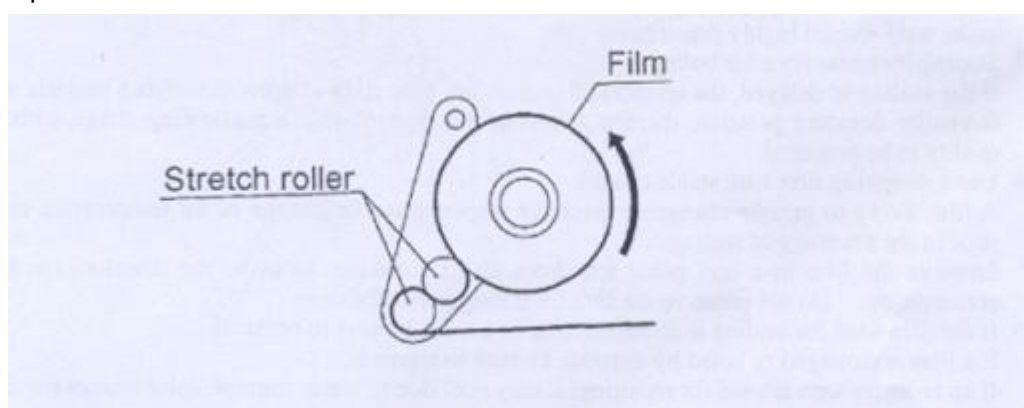

(3) Pull out the film, and pass it through as illustrated, fastening it with the twine on the bale side.

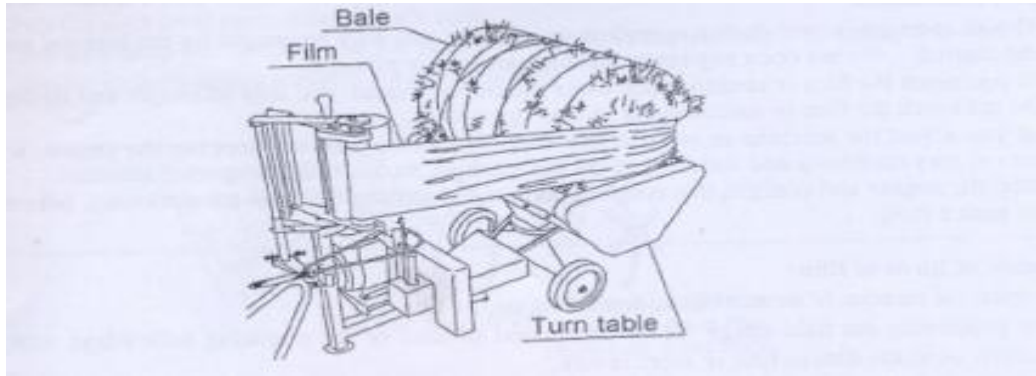

2. Adjust of side roller

(1) Place the bale to be wrapped, on the turn table alongside the side plate on the drive side (drive chain side)

(2) Adjust the side roller for adaptation to the width of the bale, and fix using a bolt and nut.

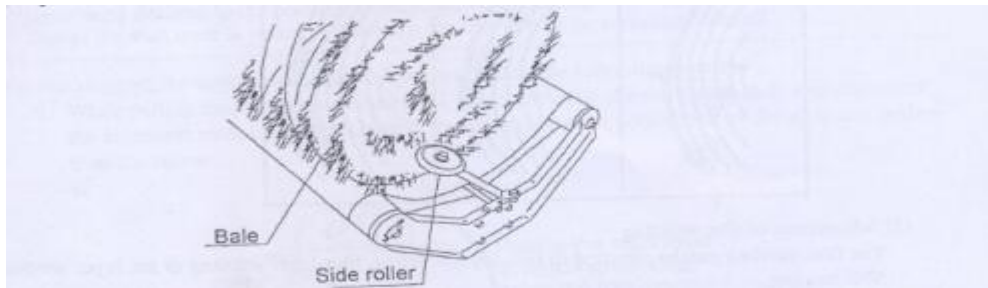

Precaution

- When adjusting the side roller, keep a spacing of about 30 to about 50mm between the end face of the bale and the side roller
- After completion of adjustment, firmly tighten the bolt and the nut

3 Working procedure

The machine is portable and can be moved. It can be used even near a livestock yard on a field.

Precaution

- Do not handle a bale of more than 30kg on this machine. Furthermore, do not throw the bale onto the turn table. Otherwise the machine may be damaged.

WARNING

- If you touch the turn table or the like during operation or rotation, you may be injured. Do not allow persons working nearby to approach the machine
- If an irregularly shaped bale or light-weight bale is going to be wrapped, it may be swung away to injure any person working nearby. Do not wrap such a bale
- If the machine is used indoors as in a house, the exhaust gas may cause poisoning. Open windows and door for sufficient ventilation.

CAUTION

- If you open any cover during operation or rotation, you may be caught by the rotating portion and injured. Do not open any cover during operation or rotation.
- If you touch the film or stretch roller while the film is wound, you may be caught and injured. Don't touch the film or stretch roller during operation.
- If you adjust the machine or remove any deposited matter without stopping the engine, a third person may carelessly and suddenly drive the machine, to cause an unexpected accident. Stop the engine and confirm that rotating portion and moving portions are stationary, before you do such a thing.

1. Number of turns of film

(!) Adjust the number of turns of film, depending on the situation.

For preserving the bale silage for a long period of time or for preparing bale silage with good quality, wind the film in four or more layers.

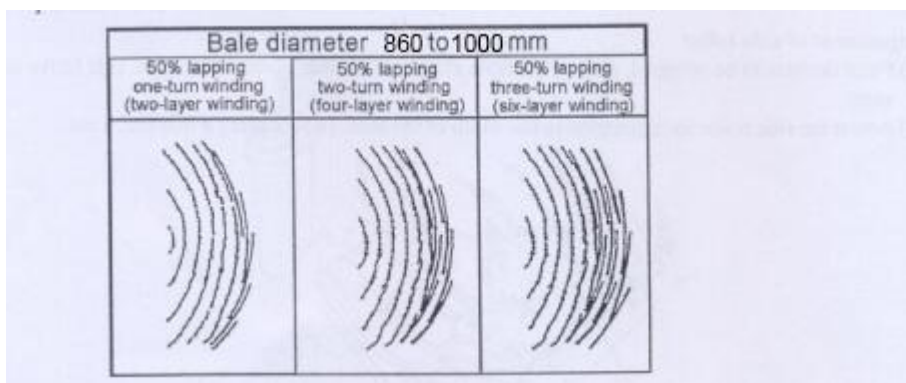

(2) Adjustment of film winding

The film winding can be adjusted to two-layer winding, four-layer winding or six layer winding in 50% lapping.

Adjust as follows:

① For two-layer winding in 50% lapping

Insert the beta pin into the "upper hole" of slide arm shaft portion of automatic stopping device

② For four-layer winding in 50% lapping.

Insert the beta pin into the "middle hole" of slide arm shaft portion of automatic stopping device

③ For six-layer winding in 50% lapping

Insert the beta pin into the "lower hole" of slider arm shaft portion of automatic stopping device.

